

460, 480 SERIES

Squeeze Action Plier Clamps | Product Overview

Features:

- Drop forged alloy steel components for exceptional strength
- Two way trigger release allows for fast and easy opening of clamp

Applications:

- Assembly
- Welding

Also Available:

See page MC-ACC-1 for accessories

462



462-2

With Two Adjustable Spindles

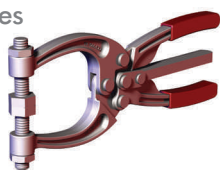

463

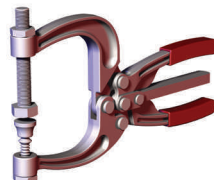

482

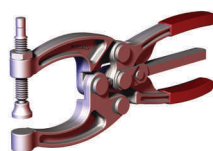

484



486

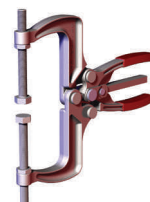

Technical Information, Holding Capacities

Model	Max. Holding Capacity	Weight	(K5) Maximum Clamping Thickness	Spindle (Supplied)
462	3110 N [700 lbf]	0,51kg [1.13lb]	29,5 [1.16]	468206-M 210206-M
462-2			30,5 [1.20]	(2X) 491203-M
463	5340 N [1200 lbf]	0,54kg [1.19lb]	54,2 [2.13]	468206-M 210206-M
482			29,5 [1.16]	468206-M
484	0,91kg [2.00lb]	76,5 [3.01]	468206-M 210206-M	
486	4450 N [1000 lbf]	1,05kg [2.31lb]	138,4 [5.45]	(2X) 240203-M

460, 480 SERIES

Squeeze Action Plier Clamps | Dimensions

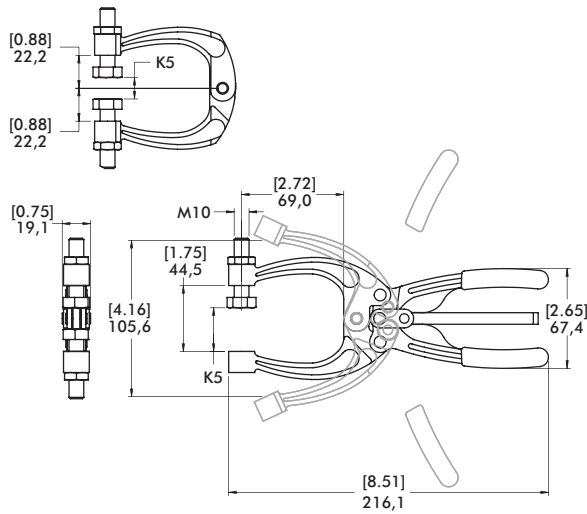

MODEL 462 AS SHOWN

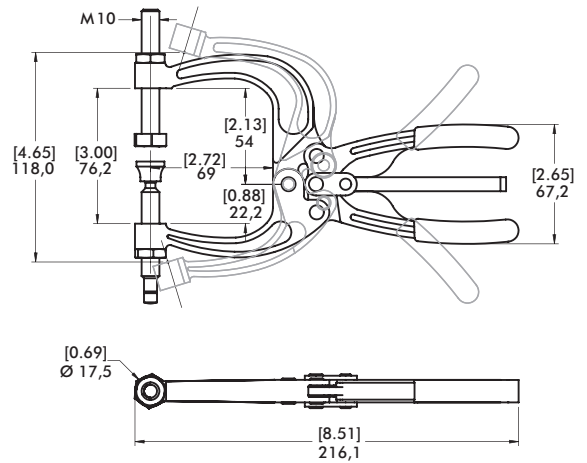

MODEL 463 AS SHOWN

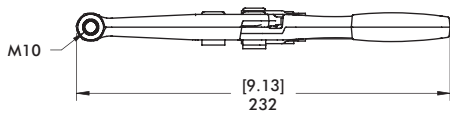

MODEL 482 AS SHOWN

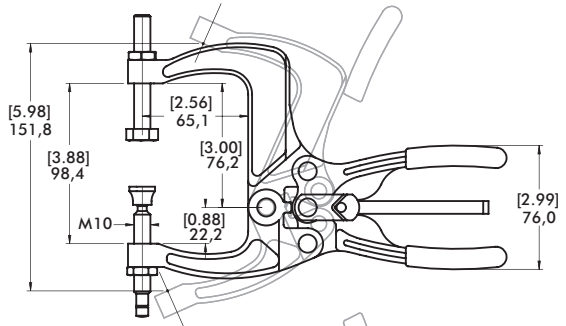

MODEL 484 AS SHOWN

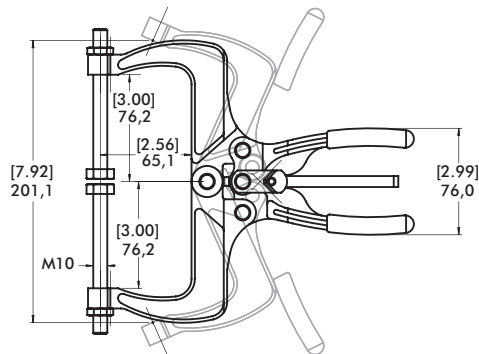
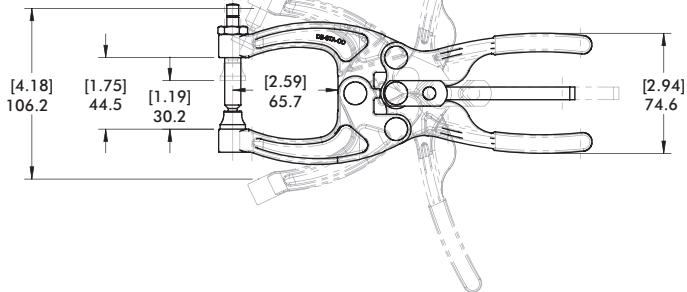

MODEL 486 AS SHOWN

mm [INCH]

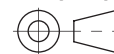

THIRD ANGLE PROJECTION