

Series 247, 267 Product Overview

Features:

- Hardened steel bushings
- Large bar guides for greater lateral stability on Model 247
- Series 247 accomodates M12 or 1/2 spindle accessory
- Series 267 accomodates M16 or 5/8 spindle accessory

Applications:

- Assembly & test
- Light machining
- Welding

Also Available:

See page 7.1 for accessories  
 847-U Pneumatic Toggle Clamp (See page 9.15)  
 847-S Pneumatic Toggle Clamp (See page 9.15)

**247-U**  
Flanged Base  
U-Bar

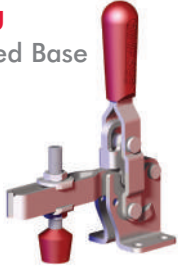

**247-S**  
Flanged Base  
Solid Bar



**247-UB** ⓘ  
Straight Base  
U-Bar

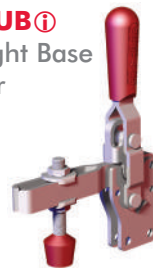

**267-U**  
Flanged Base  
U-Bar

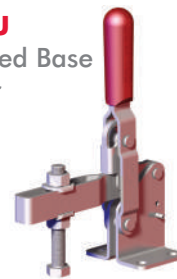

**267-S** ⓘ  
Flanged Base  
Solid Bar



Note:  
Clamps shown with included accessories.

Series 247, 267 Technical Information

Model	Max. Holding Capacity	Clamp Bar Opening (+10°)	Handle Opening (+10°)	Weight	Accessories (Supplied)		
					Bolt Retainer	Spindle Assembly	Flanged Washers
<b>247-U</b>	4400 N [1000 lbf]	120°	67°	1,07kg [2.36lbs]	---	247208-M	247109
<b>247-S</b>				1,08kg [2.36lbs]	247110	---	---
<b>247-UB</b> ⓘ				1,07kg [2.36lbs]	---	247208-M	247109
<b>267-U</b>	5340 N [1200 lbf]	140°	72°	2,18kg [4.80lbs]	---	267203-M	267102
<b>267-S</b> ⓘ				1,98kg [4.36lbs]	110122	---	---

ⓘ This item is available upon request

Series 247 Holding Capacities

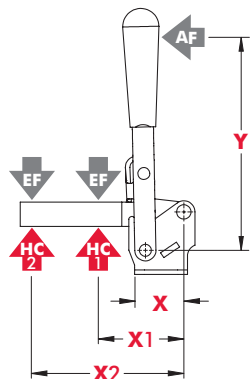

Model	X	X1	X2	Y	‡HC1	‡HC2	‡EF(X1):AF	‡EF(X2):AF
<b>247-U/ 247-UB</b> ⓘ	[1.69] 43	[3.00] 76,2	[6.13] 155,7	[6.71] 170,5	[1000lbf.] 4450N	[480lbf.] 2140N	12:1	6:1
<b>247-S</b>		[4.56] 115,8	[7.00] 177,8			[650lbf.] 2900N	10:1	5:1
<b>267-U</b>	[2.50] 63,5	[4.00] 101,6	[8.00] 203,2	[9.25] 235	[1200lbf.] 5340N	[600lbf.] 2670N	18:1	8:1
<b>267-S</b> ⓘ		[6.00] 152,4	[8.75] 222,3			[820lbf.] 3650N	12:1	

Dimensions shown "mm [inch]" ‡ HC = Holding Capacity, EF = Exerting Force, AF = Applied Force  
 Refer to page 15.4 for additional information. ⓘ This item is available upon request

## Series 247 Standard Clamp Dimensions -U/-S/-UB

**247-U**  
Flanged Base  
U-Bar

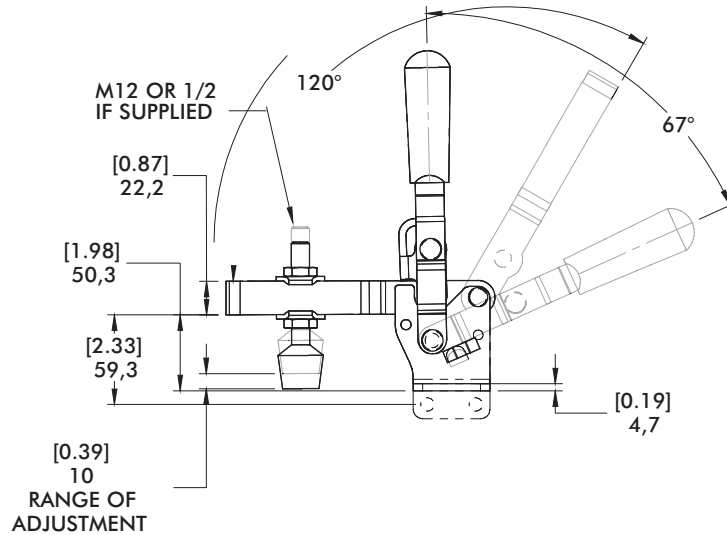
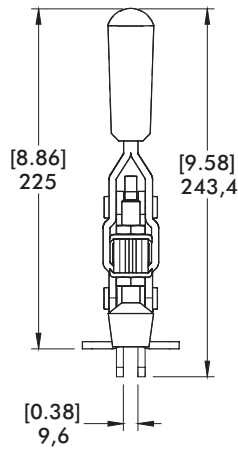
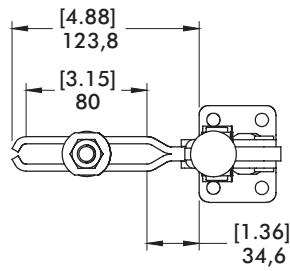
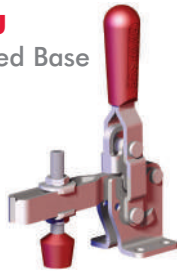

**247-S**  
Flanged Base  
Solid Bar

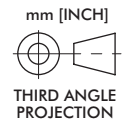
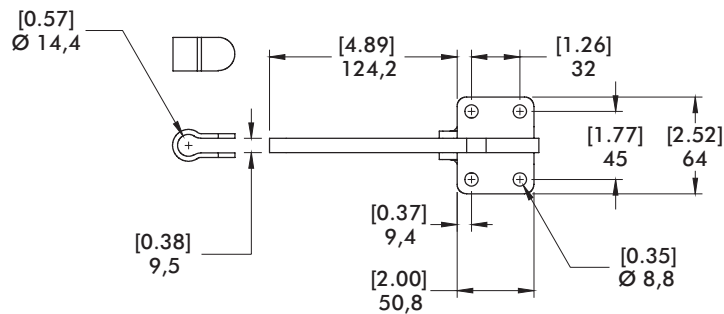

Series 267 Standard Clamp Dimensions  
-U/-S

**267-U**  
Flanged Base  
U-Bar

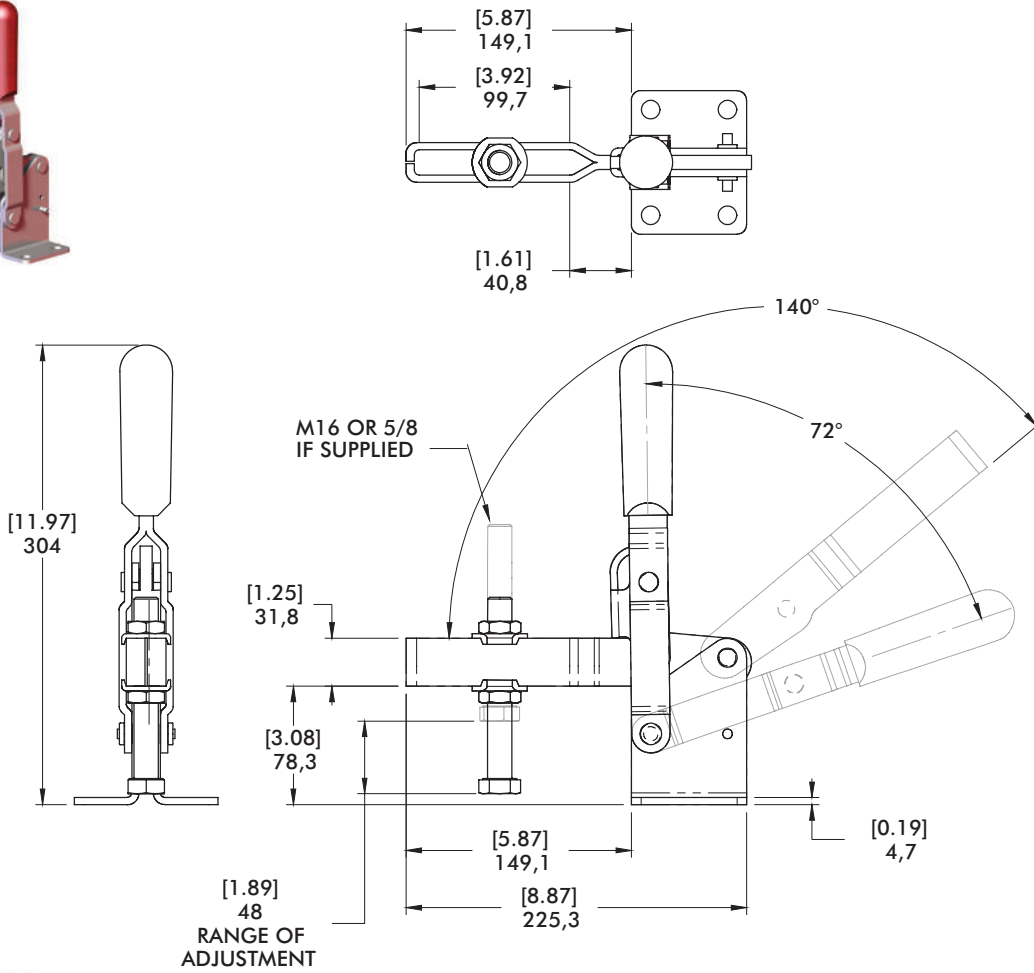
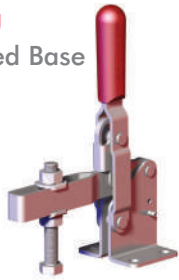

**267-S**  
Flanged Base  
Solid Bar

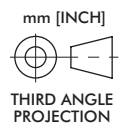
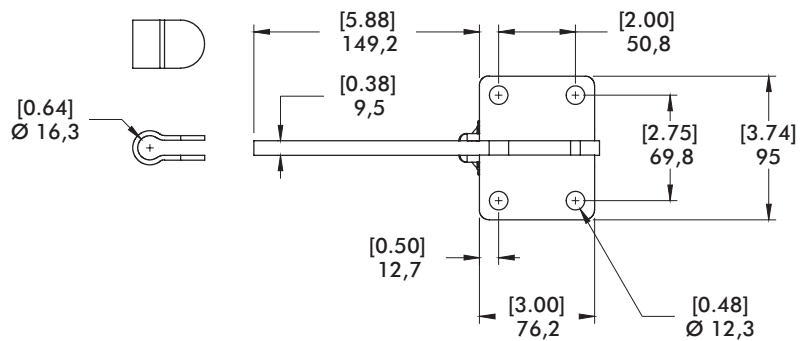

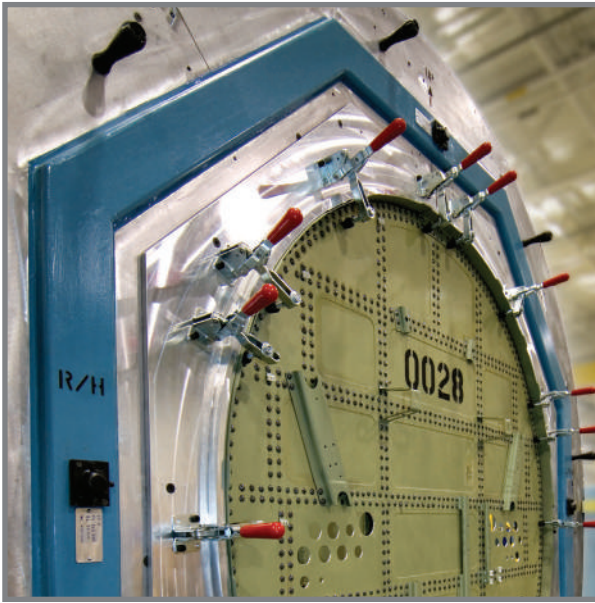

**Model 210-U**  
used in an airframe  
assembly fixture

**Model 210-U**  
shown being used  
in a checking fixture  
application.

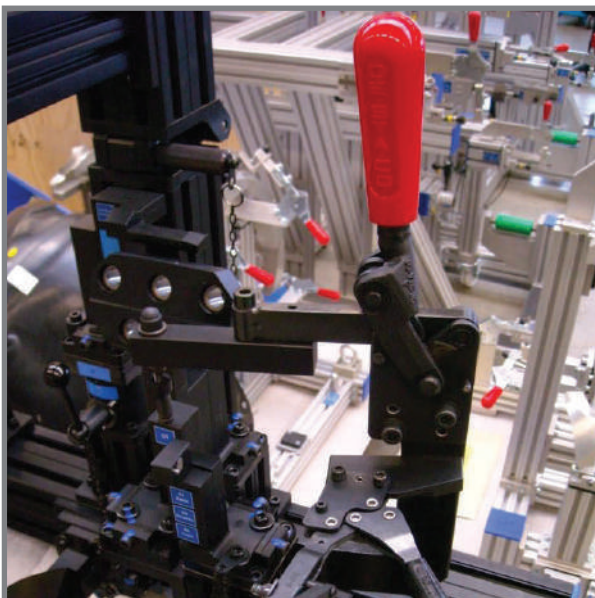
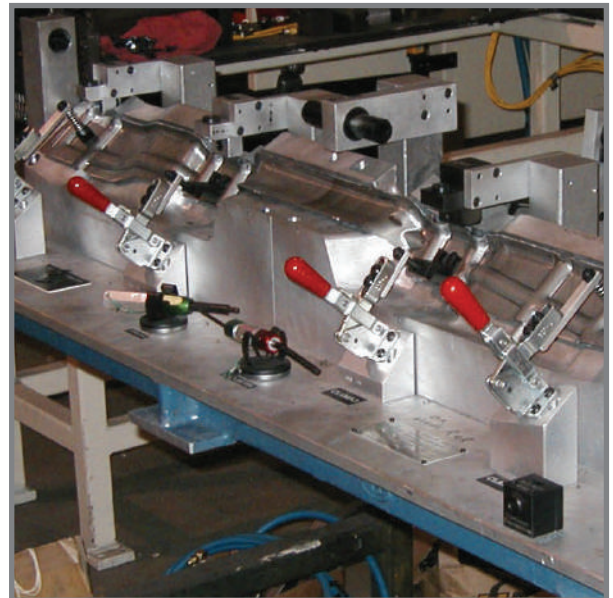

**Model 533-LB**  
and **227-UB** shown  
with black finish  
in a fixture for used for  
optical inspection.